

Streaming iPod & 192KHz Audio on Power-line Reference Design



Features

- Power-line connectivity
- Evaluation kit includes Transmitter and Receiver
- 2-channel stereo audio
- No audio compression
- Data formats: Left justified, I²S
- Optional S/PDIF transmission
- 16/24 bit resolution
- Sampling rate: 44.1KHz, 48KHz, 96KHz, 192KHz
- High SNR and THD+N
- Very short latency from transmitter to receiver(s)
- One transmitter works with multiple receivers
- Configurable delay time
- Back channel to support IR control
- L-ch & R-ch synchronization control

Introduction

The Streaming Audio Reference Design makes it easy to create powerline-enabled audio systems that can receive contents from any source in any location at home. The audio transmitter can stream stereo audio to multiple audio stations placed at any desired location – creating whole-house audio distribution without any new wiring.

Specifications

I/O and Tx Module	Input Output	Audio: 2 channels L/R RCA Jacks, 1 S/PDIF AC power-line
I/O and Rx Module	Input Output	AC power-line Audio: 2 channels L/R RCA Jacks, 1 S/PDIF
Analog Audio Mode System	Audio Input Audio Channel Sampling Rate Resolution Analog Signal Level Frequency Response	L/R RCA Jacks for Stereo Audio Two Channels 48 KHz / 96 KHz /192 KHz selectable 16 or 24 bit selectable 3 Vp-p maximum 20 Hz to 22 KHz 0.2 dB at 48 KHz sampling rate 20 Hz to 40 KHz 0.2 dB at 96 KHz sampling rate 20 Hz to 80 KHz 0.2 dB at 192 KHz sampling rate
	SNR Dynamic Range THD+N Channel Separation Tx Input Impedance Rx Output Impedance	105 dB (typical)* 105 dB (typical)* -96 dB (typical)* 48 KHz sampling 102 dB @ 1 KHz, -1 dB full scale* 15 KOhm (typical)* 10 KOhm (typical)*
		*Note: Reference data refers to the AKM Semiconductor AK5381/AK5386 ADC and AK4388 DAC.
S/PDIF Audio Mode System	PCM Mode Data Mode Sampling Rate Data Format S/PDIF Connector	2 channels AC3/dts/other compressed data 32 KHz, 44.1 KHz, 48 KHz, 96 KHz, 192 KHz 24-bit I ² S, 16-bit I ² S, 24-bit or 16-bit left justified Tx: 75 Ohm coaxial cable & optical cable Rx: 75 Ohm coaxial cable & optical cable
Network Transmission	Transmission Media Latency Time Transmission	Ethernet RJ45 or Power Line Short distance: < 10ms, programmable Long distance: 100 ms to 2 sec. programmable One to Three
iPod® Dock	Apple® iPod® input	Apple® iPod® docking connector Supports iPod® nano, iPod® classic, iPod® touch and iPhone™ Remote controller for iPod® control, such as volume, up, down, etc. Supports remote-control for iPod® operations
IR Remote	IR Blaster (Rx to Tx)	Supports 36KHz, 38KHz, 40KHz and 56KHz
Power Consumption	Tx Module Rx Module	100 to 240 VAC @ 10W max. 100 to 240 VAC @ 10W max.
Environment	Temperature	Operating: 10 to 55 degrees C, Storage: -20 to 70 degrees C
Physical Dimensions	Transmitter Receiver	150mm (W) X 185mm (L) X 40mm (H) 150mm (W) X 185mm (L) X 40mm (H)

Remark: All trademarks or registered trademarks belong to their respective owners.

Block Diagram

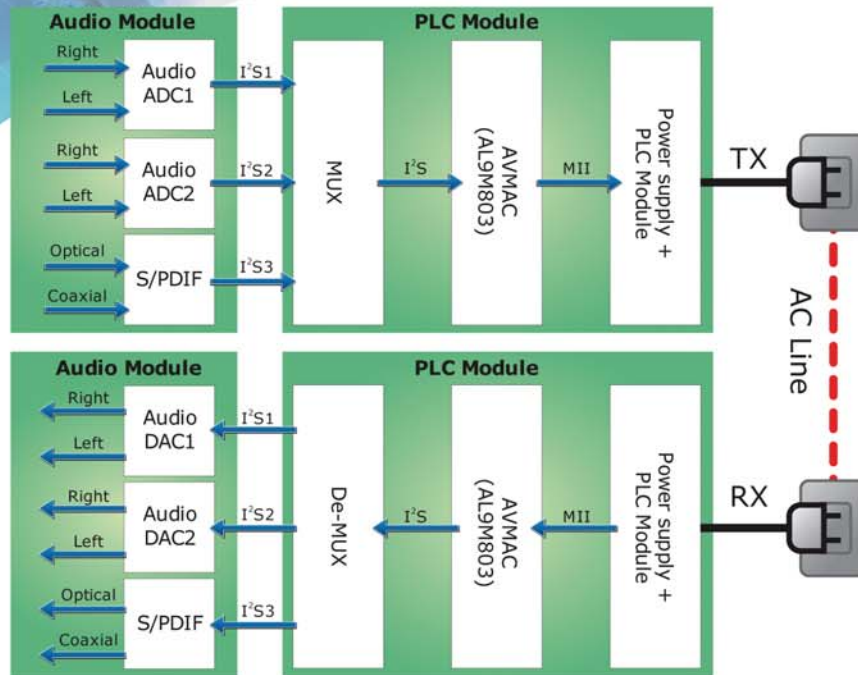

Application Scenario

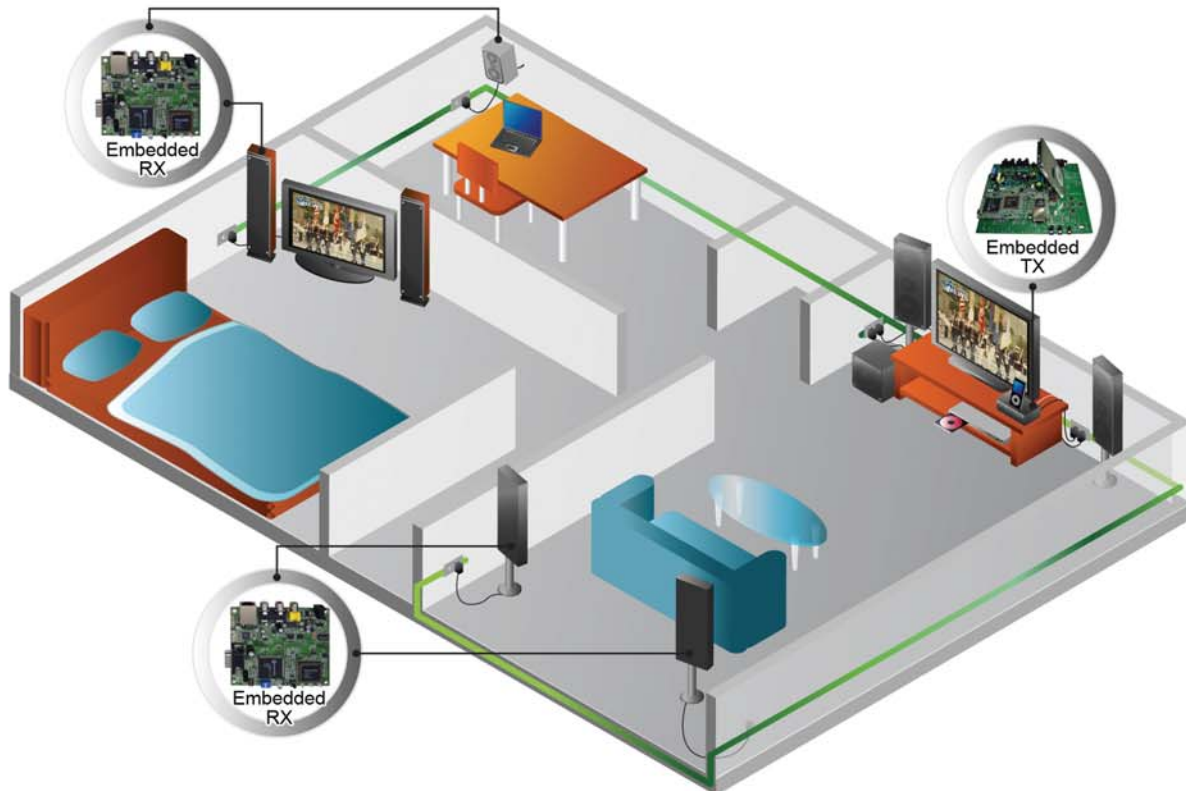

Ordering Information

EVB:

AL9M803B-EVB-A0T (TX module)
 AL9M803B-EVB-A0R (RX module)
 *A pair of Audio EVB(TX + RX modules)

Design Kits:

AL9M803B-SDK-A0

- User manual

- Free one pair of Audio TX + RX (included)
- Application notes of SW and HW (including the application note, EVB block diagram, EVB features supported, HW design guide, HW layout guide, SW guide, etc.)
- Schematic (DSN)
- BOM list
- Brief AL9M803 datasheets